



# H-3553T

BUBBLER / PRESSURE SENSOR

# CONTENTS & WARRANTY

This user manual is a guide for the H-3553T. For more information, updated manuals, brochures, technical notes, and supporting software on the H-3553T, please refer to [waterlog.com/3553](http://waterlog.com/3553) or contact your sales representative.

For additional assistance, please contact us at +1.435.753.2212 or [sales@waterlog.com](mailto:sales@waterlog.com)

<b>WaterLOG® Warranty</b> .....	1	4-20 Milliamp Max Stage.....	23
<b>Chapter 1: Introduction</b> .....	2	Modbus Mode Enable.....	24
Bubbler Features.....	3	Auto Mode Enable.....	24
<b>Chapter 2: Getting Started</b> .....	4	Measure Rate (Auto Mode Enabled).....	25
What's in the Box.....	5	Test Display.....	26
Product Description.....	6	Help.....	26
Initial Testing.....	6	Setup and Operation Conclusion.....	26
Power-up.....	6	<b>Chapter 5: Modbus Operation</b> .....	27
Using the Display.....	7	Communication Setup.....	28
Make Measurement.....	7	Function Codes.....	28
<b>Chapter 3: Installation</b> .....	8	Holding Registers.....	28
Water Depth.....	9	ID String Registers.....	29
Mounting.....	9	Modbus Address Register.....	29
Desiccator.....	9	Stage Units Select Register.....	29
Orifice Line.....	9	Baudrate Select Registers.....	30
Power Wiring.....	10	Parity Select Registers.....	30
<b>Chapter 4: Setup &amp; Operation</b> .....	11	Bubble Rate Register.....	30
RS-232 Menu.....	12	Purge Pressure Register.....	30
RS-232 Print Out.....	12	Purge Sustain Register.....	30
SDI-12 Interface.....	13	Purge Register.....	30
Default Setup.....	14	Stage Offset Register.....	30
Reset to Defaults.....	14	Stage Slope Register.....	31
SDI-12.....	15	Stage Register.....	31
Stage Units/Slope.....	15	Pressure Register.....	31
Set Current Stage.....	16	Temperature Register.....	31
Stage Offset.....	17	Control Battery Register.....	31
Stage Averaging Time.....	17	Tank Pressure Register.....	31
RS-232 Stage Digits.....	18	Compressor Battery Register.....	31
Bubble Rate.....	19	Modbus Command Examples.....	31
Purge.....	20		
Purge Pressure.....	20		
Purge Sustain.....	21		
4-20 Milliamp Output.....	22		
4-20 Milliamp Min Stage.....	22		

"WATERLOG™ PRODUCTS MANUFACTURED BY YELLOW SPRINGS INSTRUMENTS CO., INC. are warranted by Yellow Springs Instruments Co., Inc. ("YSI") to be free from defects in materials and workmanship under normal use and service for twelve (12) months from date of shipment unless otherwise specified in the corresponding YSI pricelist or product manual.

WaterLOG™ products not manufactured, but that are re-sold by YSI, are warranted only to the limits extended by the original manufacturer. Batteries, desiccant, and other consumables have no warranty. YSI's obligation under this warranty is limited to repairing or replacing (YSI's option) defective products, which shall be the sole and exclusive remedy under this warranty.

The customer shall assume all costs of removing, reinstalling, and shipping defective products to YSI. YSI will return such products by surface carrier prepaid within the continental United States of America. To all other locations, YSI will return such products best way CIP (Port of Entry) INCOTERM® 2010, prepaid. This warranty shall not apply to any products which have been subjected to modification, misuse, neglect, improper service, accidents of nature, or shipping damage. This warranty is in lieu of all other warranties, expressed or implied. The warranty for installation services performed by YSI such as programming to customer specifications, electrical connections to products manufactured by YSI, and product specific training, is part of YSI's product warranty. YSI EXPRESSLY DISCLAIMS AND EXCLUDES ANY IMPLIED WARRANTIES OF MERCHANTABILITY OR FITNESS FOR A PARTICULAR PURPOSE. YSI is not liable for any special, indirect, incidental, and/or consequential damages."

A complete TERMS AND CONDITIONS OF SALE can be viewed at:  
<http://www.ySI.com/terms-and-conditions.php>

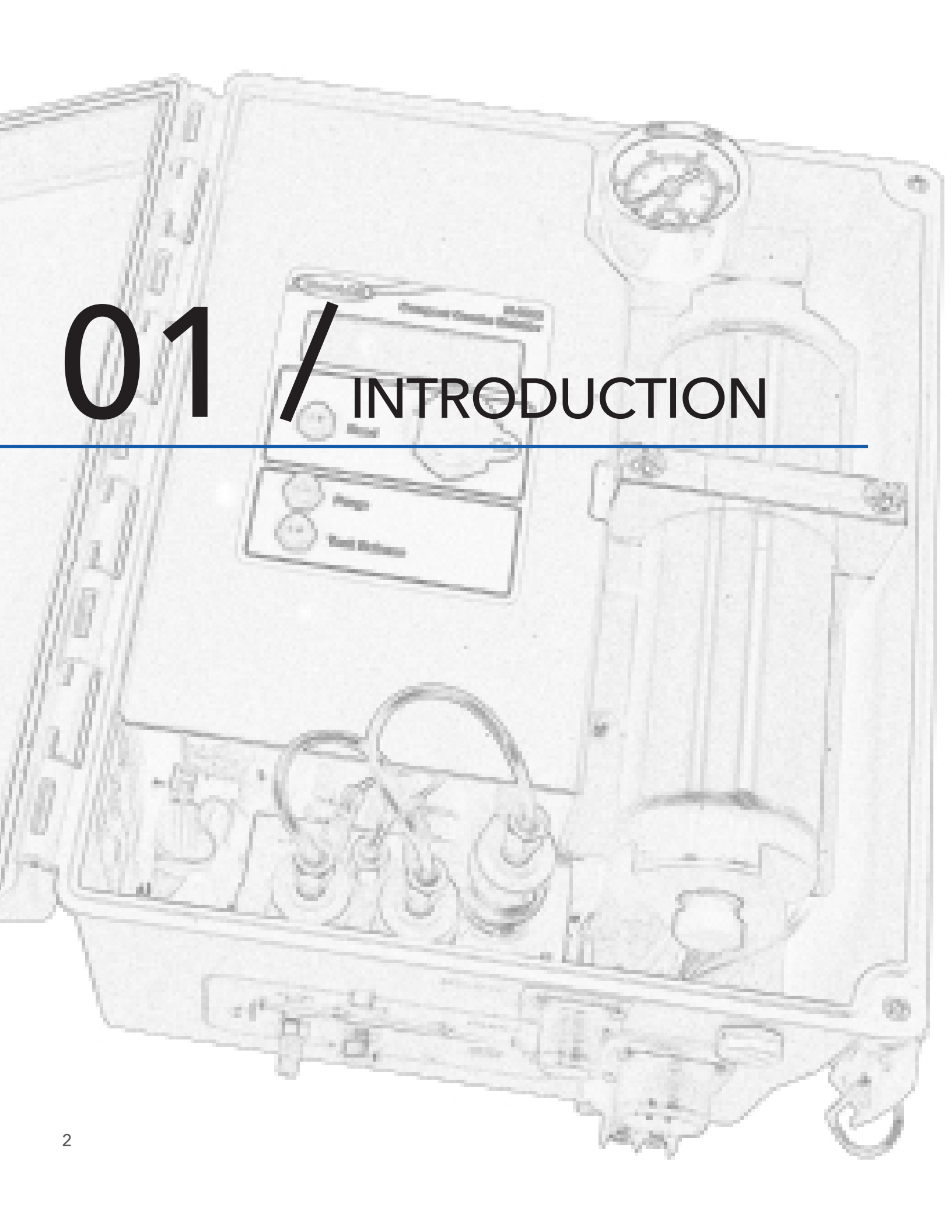

# 01 / INTRODUCTION

---

The WaterLOG® H-3553T/ Pressure Sensor is well known for its compact size and combination of a Bubbler and built-in pressure sensor. The H-3553T has also been referred to as a self-contained “smart” gas purge system, because it produces a precision constant mass flow of gas.

Designed to measure fluid levels in surface water, ground water and tanks, the H-3553T Modbus or Auto mode is enabled it will enter the RS-232 menu with any character sent to this port. uses a battery operated compressor to maintain pressure in an internal tank. A microprocessor determines how much pressure is needed in the tank, based on the current head pressure, to produce a constant bubble rate. The compressor and tank replace the dry nitrogen tank used in previous systems to ensure a safer site.

A sophisticated system of sensors and valves to regulate the bubble rate and purge pressure replaces the sight feed flow controller and pressure regulator (Conoflow system) used in previous systems. A purge feature, temporarily pumps up the tank and opens a valve to apply high pressure to the orifice line. This feature is designed to remove any sediment that may have collected in or around the outlet of the orifice line.

The H-3553T is a standalone system to be used with a Data Collection Platform (DCP). Additional programming options and an H-3553T built-in menu, make the XL series DCP's a favorite when it comes to selecting a data logger to pair with this Bubbler.

### Key Features:

- Easy to use stand-alone RS-232 menu setup
- Built in calibrated pressure sensor
- No external pressure sensor needed
- RS-485 MODBUS Client/Slave device (available in V1.3 or later)
- Auto update mode, measures itself based on user defined rate
- SDI-12 interface, 4 - 20mA output, and RS-232 data output

### Display Features:

- Continuous display readout always shows last measured value
- ‘Read’ button causes the H-3553T to initiate a new measurement
- ‘Purge’ button causes the H-3553T to initiate a line purge
- ‘Tank Release’ button causes the H-3553T to release the pressure from the tank
- The adjust knob allows the user to manually set the stage and sensor SDI-12 address

### Other Features:

- Provides a continuous gas flow
- Battery operated - Low power
- Microprocessor controlled, “smart” gas system
- One-piece manifold eliminates many potential sources of leaks
- Pressure gauge provides a visual indication of the tank pressure
- Hydrophobic intake membrane, protects compressor
- All components are easily accessible for inspection and maintenance
- Piston type compressor does not use diaphragm
- Provides an internal pressure relief valve
- Compressor is designed and rated for cold temperature operation
- Controlled and monitored as an SDI-12 sensor

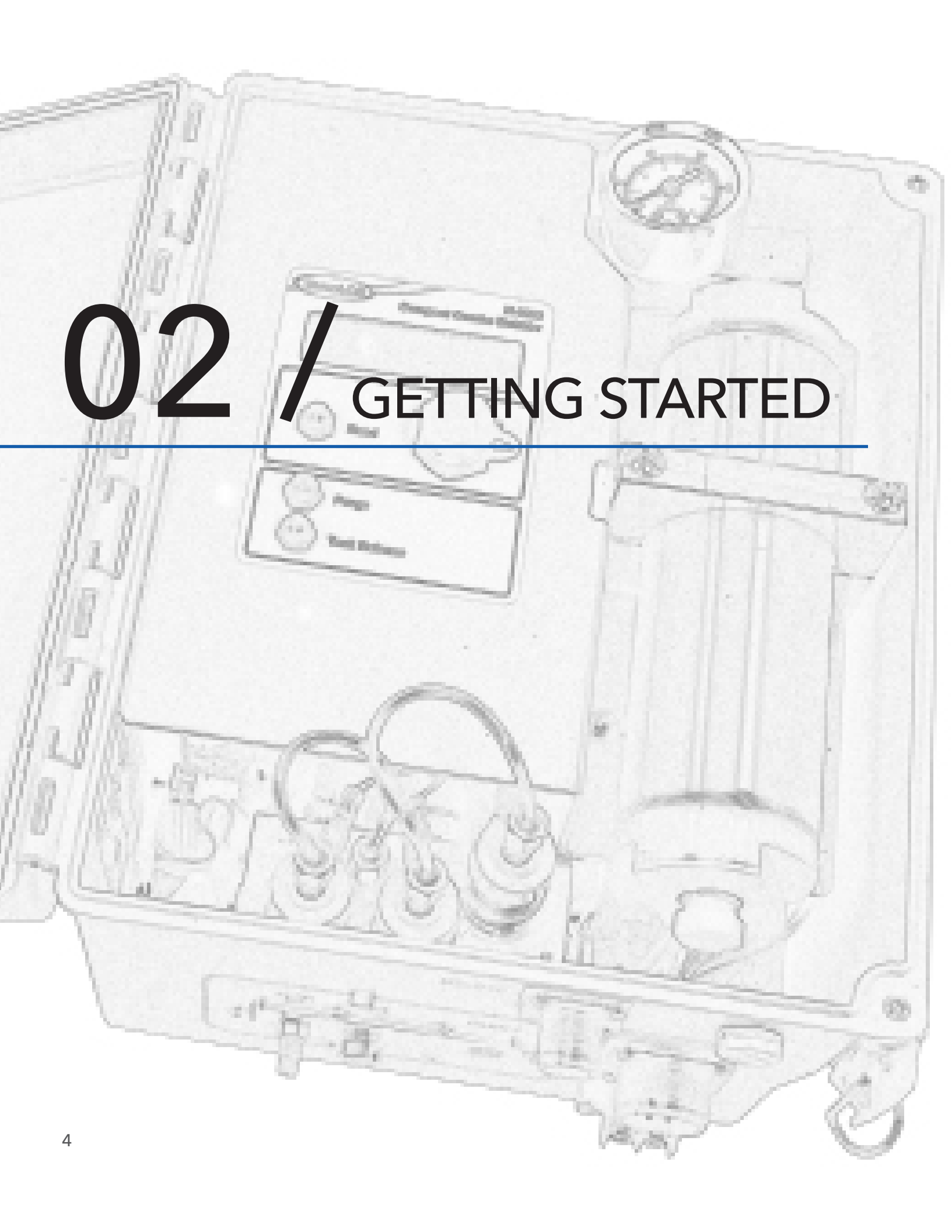

# 02 / GETTING STARTED

---

## Getting Started

Before installation, setup and operation of the H-3553T in the field, read through this section for a general overview of what you have and how to use it.

### What's in the Box

When unpacking your H-3553T, make sure all the components ordered are received and undamaged from shipping. The **basic package includes:**

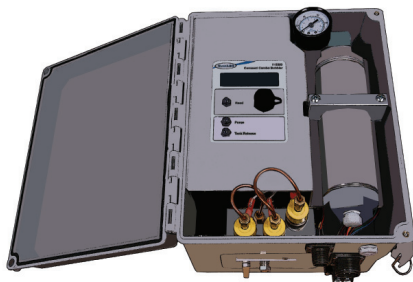



---

H-3553T Bubbler

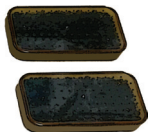

---

7 Pin Interface Cable



---

(2) Desiccant Canisters



---

1/4" Tubing to 1/8" NTP Connector



---

Mounting Hardware

### Optional Items:

- Desiccating Air Dryer
- Orifice Installation Kit
- Orifice Line (1000 ft. minimum)
- RS-232 Communications Cable
- Replacement Air Dryer Desiccant

# GETTING STARTED

## Product Description

It is important to familiarize yourself with the connections before installing a product at the site. Below are standard connections found on the H-3553T.

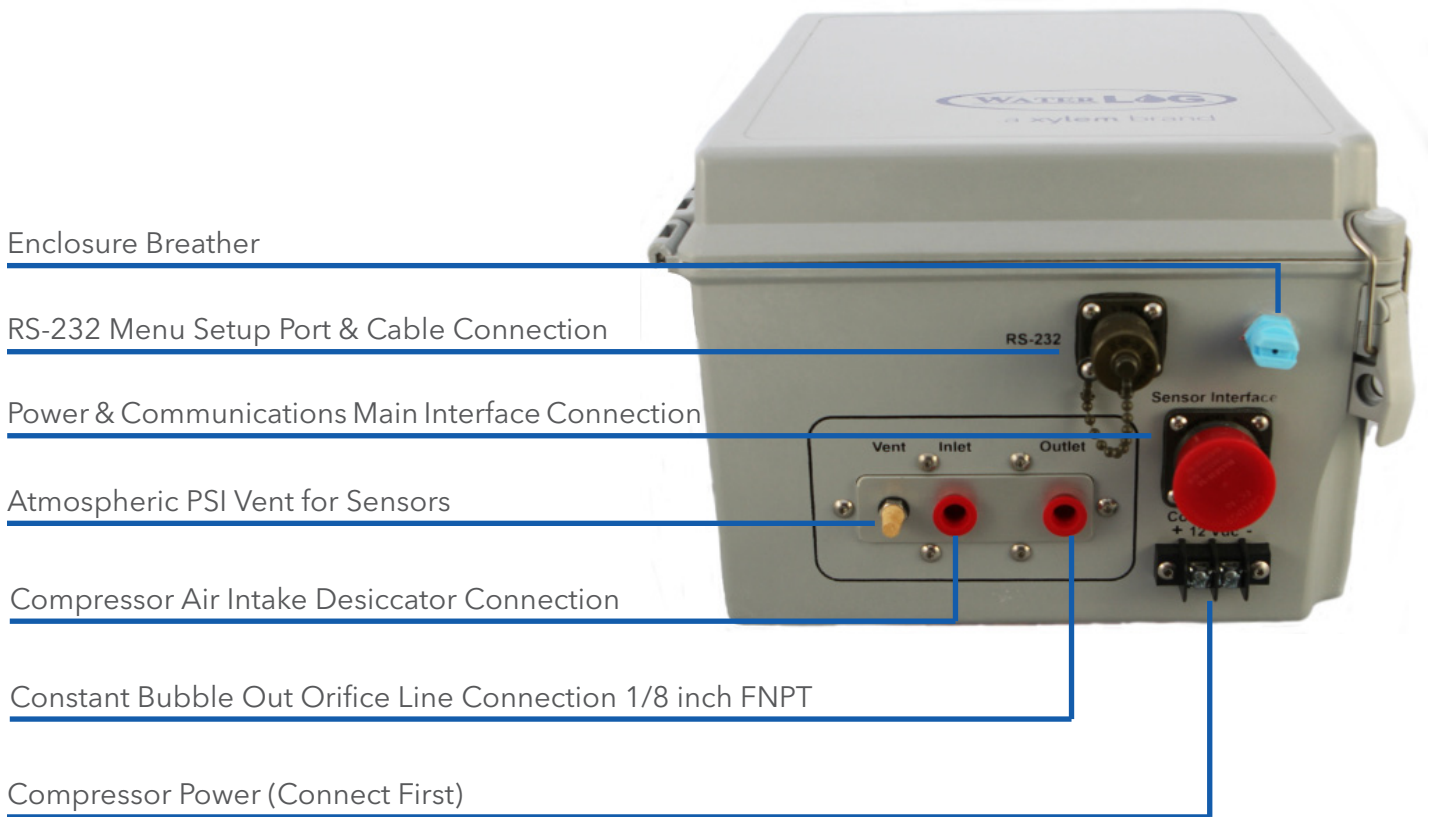

## Initial Testing

Before installing the H-3553T in the field, it is a good practice to test the system in the shop or lab. This will help preparations for a successful field install.

## Power Up

Follow these steps to power up the H-3553T:

1. Apply +12v to the "Compressor 12VDC" terminal connections
  2. Referring to Table 2-1, connect +12 VDC, GND, and SDI-12 data connections of the 7 wire Main I/O sensor interface pigtail cable to a SDI-12 master device, such as a WaterLOG® XL series DCP.
  3. Verify the connections Table 2-1, and then connect the Main I/O sensor interface pigtail cable to the H-3553T via the 7 pin "Sensor Interface" military grade connector.
  4. At power up, the H-3553T will take an initial atmospheric measurement (listen for a "click" while the sensors are switched to atmosphere) and then if needed the compressor will turn on to initialize the tank pressure.
- 6



## Getting Started

### Using the Display

The H-3553Ts display has a 'Read' button that when pressed will cause the unit to initiate a new measurement and update the display. Measurement requests from an attached SDI-12 data logger will also cause the display to update.

If the 'Read' button is pressed and held until the display starts flashing, the Adjust screw may be turned to increase or decrease the current stage value. Turning the Adjust screw slowly will change the hundredths (or thousandths based on the digit setting) digit while turning the screw fast changes the ones digit. This allows one control to make both fine and course adjustments.

If the 'Read' button is held down while the H-3553T is being powered up, the display will show the current SDI-12 address. The SDI-12 address may be changed using the Adjust screw. Turning the Adjust screw will change the address in the range of 0 to 9. When the Read button is released the new SDI-12 address is saved and the display switches to the normal stage readout. To change the SDI-12 address again, the power must be disconnected and the special power-up sequence repeated.

When the 'Purge' button is pressed a new measurement will be initiated; following the measurement, a line purge will begin. For more information see the Purge section in Chapter 4.

When the 'Tank Release' button is pressed the valve holding the air in the tank will be opened, allowing the air stored in the tank to be released. This button can be useful when troubleshooting the unit.

### Make Measurement

Using a SDI-12 master device, like the XL series DCP, send the "0M!" measurement command to the H-3553T. Wait about 6 seconds, and then send the "0D0!" data command and verify the data retrieved with the example below.

Data format: "a + A.AA + B.BBB + CC.C + DD.D + E.EE + FF.F"

- a = SDI-12 sensor address
- A.AA = Stage (Feet)
- B.BBB = Pressure (PSI)
- CC.C = Temperature (°C)
- DD.D = Sensor Interface Battery (Volts)
- E.EE = Tank Pressure (PSI)
- F.FF = Compressor Battery (Volts)

Example: "0 + 1.35 + 0.585 + 19.8 + 13.6 + 3.55 + 12.3"

Table 2-1: Main I/O Sensor Interface Cable

Colors	Signal	Cable/Bulkhead
Red	+12 VDC	F
Black	GND	E
Yellow	SDI-12 Data	G
Blue	4-20mA +	C
Green	4-20mA -	D
Orange	RS-485+	A
Brown	RS-485-	B

# 03 / INSTALLATION

---

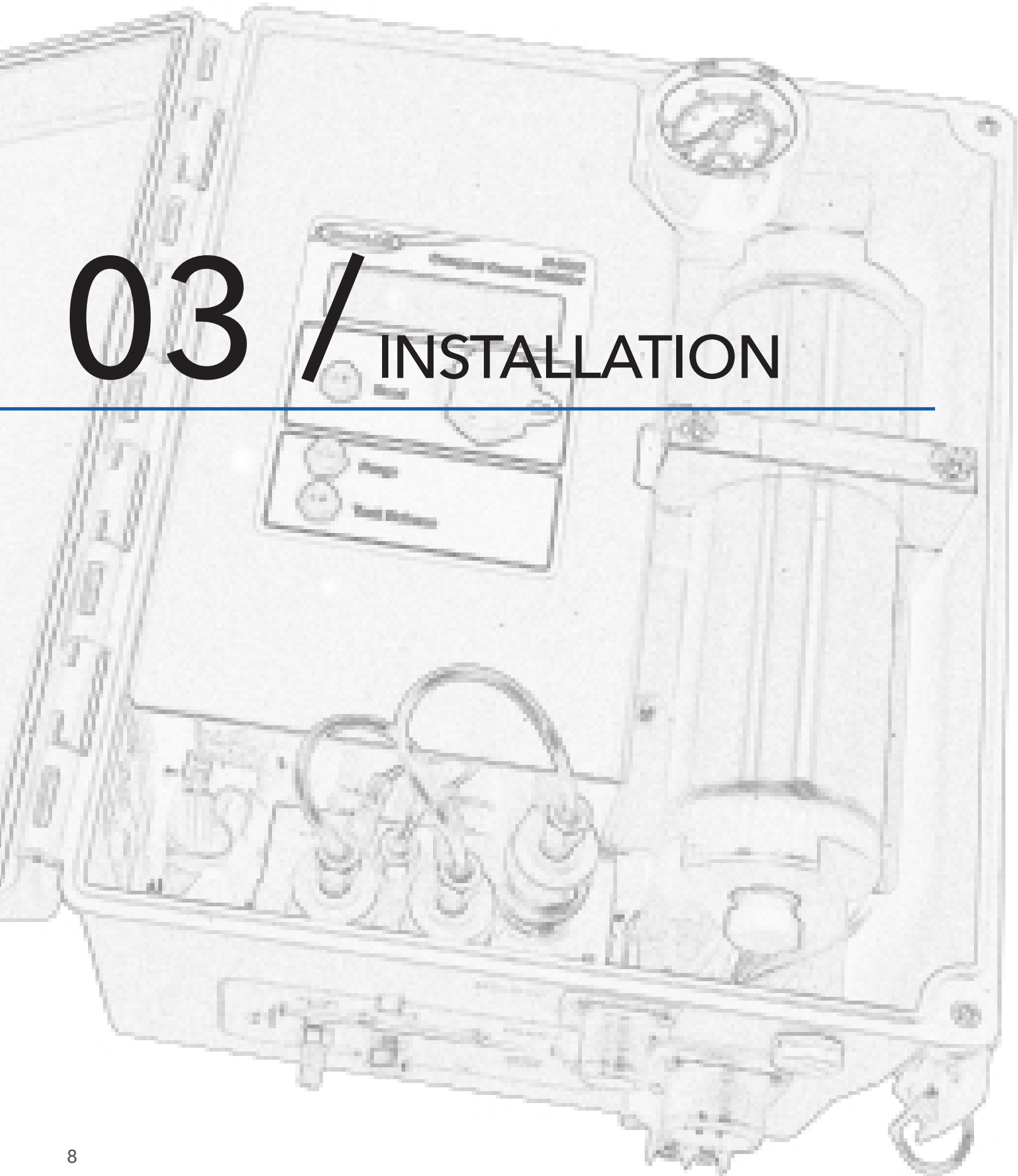

## Installation

The WaterLOG® H-3553T is a system with a fully integrated digital pressure transducer specifically designed for water level monitoring. The H-3553T directly measures dry gas over a broad temperature range.

**WARNING!** Before proceeding with the installation, please consider the following site preparation steps to help prevent problems later.

### Water Depth

Table 3-1 shows the maximum pressure to which the H-3553T is factory calibrated to measure. The sensor can survive temporary operation up to twice the maximum rated pressure for the model's range. However, any measurements made beyond the rated pressure will be inaccurate.

\*NOTE: Depth calculations are derived from the standard equation that one PSI is generated by a column of water 2.3067 feet deep.

Table 3-1: Models Pressure Ranges

Model	Pressure Range	Water Depth Range*	Accuracy
	0-15 PSI	0-34.60 Feet	+/- 0.007 Feet
	0-30 PSI	0-69.20 Feet	+/- 0.014 Feet

### Mounting

Consideration should be taken in properly mounting the H-3553T system. First, attach the included mounting feet to the H-3553T enclosure. Mount the H-3553T in a location where it will not get jarred or will shift during operation.

When possible mount all equipment with connectors pointing down so that moisture or condensation that could rest on the connectors does not penetrate the inner components of the equipment. Also, specifically with the H-3553T, having it mounted vertically helps prevent moisture from migrating to the valves. If moisture does migrate, it will migrate first at the bottom of the tank and near the nylon plug.

### Desiccator

Generally, an external desiccator is required to dry the compressor intake air. The desiccator prevents accumulation of moisture in the tank, manifold and other areas in the system. Connect the output of the desiccator to the port marked "Inlet". Desiccators which employ "indicating" silica gel have the advantage of visually showing the status of the desiccant. As the gel becomes saturated with moisture the gel changes from blue to pink.

### Orifice Line

The position and installation of the orifice line is vital to a successful and accurate H-3553T installation. These are just a few of several things to consider when installing or checking an orifice line installation. Refer to "Application Note 1005" for more detailed information about orifice line installation.

Be sure the water current or flow is not pushing against the end of the orifice line, as it will cause a pressure to be placed on the line that is not related to the water depth. Also, be sure the water current or flow is not pulling or drawing from the end of the orifice line, as this will cause a false lower pressure on

# GETTING STARTED

the line not related to the water depth. The line should be installed in an area where the flow of water will remain relatively calm as compared to the real stage changes. Here are a few Do's and Do not's on mounting the line.

## Do:

- Mount the outlet in still water.
- Mount the outlet so the last inch or so is almost horizontal, (slightly downward side exit).
- Try to prevent swells in long runs of orifice line (upward then downward sections).
- Use a muffler in more turbulent waters.

## Do not:

- Do not mount the outlet facing up stream, downstream, or upwards.
- Do not allow any portion of the line to be lower than the exit point.
- Do not allow "goose necks" in the orifice line.
- Do not use thin walled tubing, only use USGS approved orifice line.
- Do not mount outlet in the wake of an obstruction, bridge pier, rock, etc.

## Power Wiring

The H-3553T has two power connections. The first is the 2 position terminal strip labeled "Compressor 12VDC". This connection provides power to the compressor and the control valves. It is recommended using heavier gauge wire (about 18AWG) for this connection and connecting it directly to the gauge station + 12V battery.

The second power connection +12V through the circular connector labeled "Sensor Interface". This connection is the power connection for the circuit board or control module board. It is recommended to power the control module board via the DCP +12V input instead of using the +12V switched output. Table 3-2 shows the wiring for connecting the H-3553T to an XL Series DCP.

**Note:** It is recommended to connect the "Compressor +12VDC" power source first, then the "Sensor Interface" control module board power second. This is because the H-3553T makes an initial measurement at power up and without the compressor and control valves powered the H-3553T cannot take an atmospheric measurement to adjust for barometric pressure.

Table 3-2: H-3553T to XL Series DCP Wiring

H-3553T	XL Series DCP
Red (+12V)	+12V
Black (Gnd)	Gnd (SDI-12)
Yellow (SDI-12)	Data (SDI-12)

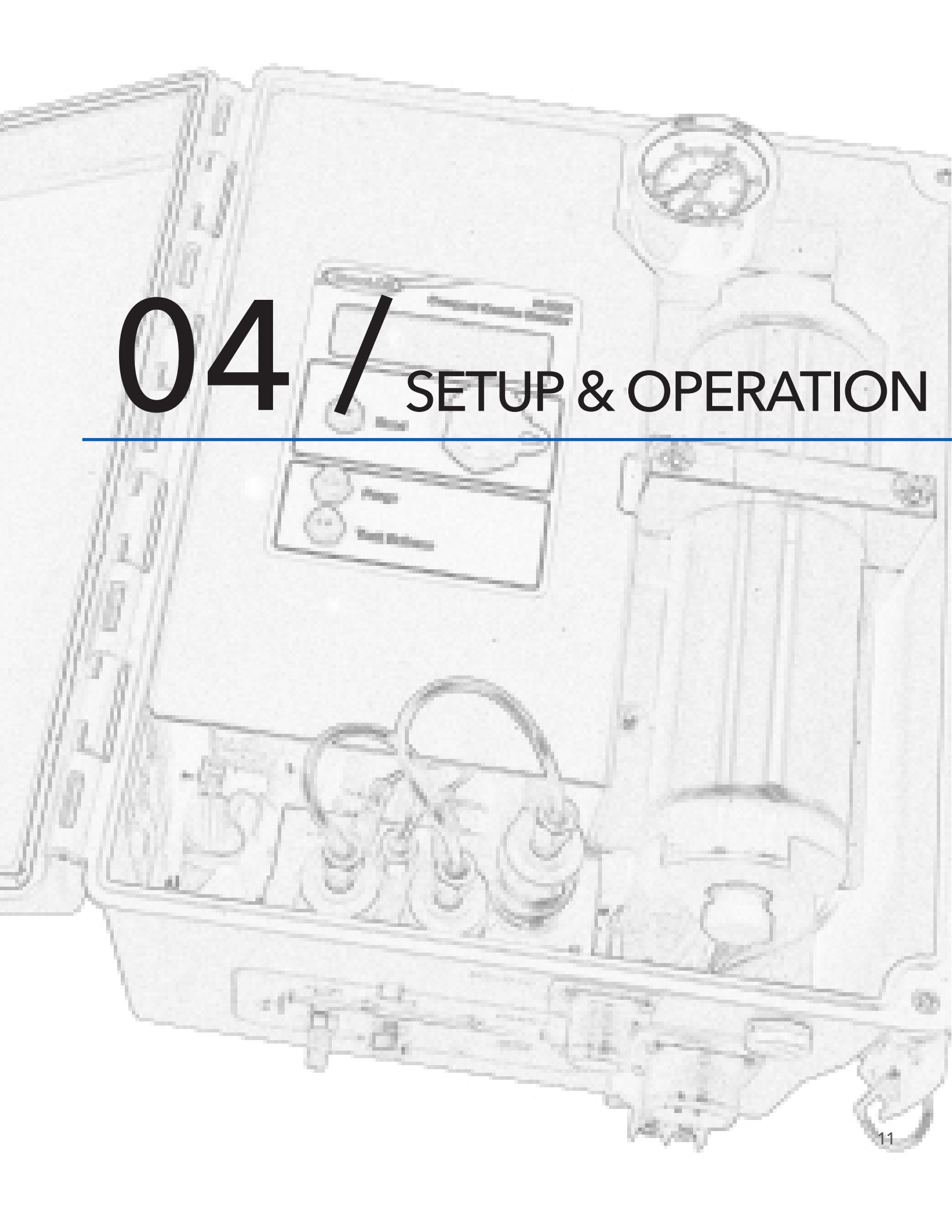

# 04 / SETUP & OPERATION

---

# SETUP & OPERATION

There are three ways to setup and operate the H-3553T, through the RS-232 menu interface, the SDI-12 interface, and through the XL series DCP menu interface. Setup through the XL series DCP menu is not discussed in this manual but is discussed in the XL series manual. This chapter will focus on setup using the RS-232 menu interface and the SDI-12 interface.

## RS-232 Menu

The RS-232 Menu interface is designed to work with a terminal emulator program such as HyperTerminal, TeraTerm, and ProComm. Table 4-1 shows the settings required to communicate with the H-3553T through the RS-232 port.

To begin using the RS-232 H-3553T menu interface, connect the H-3553T to a computer or other DTE device with 9 pin serial port using the optional H-3553T 3 pin RS-232 communications cable (H-3531-3PCABLE). Now, open the terminal emulator program and press the 'Enter' key two times on the computer keyboard to wake up the H-3553T and enter the menu. Pressing the 'Enter' key once will just force a measurement and not enter the menu. Pressing the 'Enter' key sends a carriage return (CR) and line feed (LF). Initial H-3553T communication via the RS232 serial port forces a new measurement to be executed which will print out the message, "Measuring..." When the new measurement is complete the menu below will be displayed in the terminal emulator window as long as the 'Enter' key was press two times.

## RS-232 Print Out

The RS-232 port on the H-3553T is primarily used for setup and operation, but can also be used for sending the current stage and temperature data. When the H-3553T makes a new measurement it will print the following data message out the RS-232 port.

Stage = +1.23  
Temp = +12.3

The RS-232 port can also be used to initiate new measurements. This is done by sending any character to the H-3553T RS-232 port and the H-3553T will make a new measurement and print out the above mentioned data message out the RS-232 port. Note: When the H-3553T Modbus or Auto mode is enabled it will enter the RS-232 menu with any character sent to this port.

Table 4-1: H-3553T RS-232 Communication Settings

Setting	Default Setting
Baud Rate	9600
Data Bits	8
Stop Bits	1
Parity	None
Duplex	Full
Emulation	VT-100
Flow Control	None

```
H-3553 Combo Bubbler Setup Menu

A - SDI-12 Address: 0          Serial#: 001000
                               Version: 1.00
B - Bubbler Settings
P - Advanced Options          Main Battery: +13.6
                               Pump Battery: +12.0

Stage Setup:
S - Stage: +0.00              Tank Pressure: +3.24
D - Digits: +2                Line Pressure: +.50
O - Offset: +0.0000           Temperature: +20.5
U - Units: Feet
L - Slope: +2.30670

M - Measure
X - Exit

Enter Option >
```

## SDI-12 Interface

The SDI-12 interface is another way to setup and operate the H-3553T. The H-3553T supports all standard SDI-12 commands and uses some SDI-12 extended (manufacturer specific) commands for setup operation. SDI-12 standard and extended commands are normally sent from a SDI-12 master device, like the Waterlog XL series DCP. Table 4-2 is a list of the standard SDI-12 commands and the extended SDI-12 commands for setting up the H-3553T.

Table 4-2: H-3553T Standard and Extended SDI-12 Commands

Command	Description	Command	Description
Standard SDI-12 Commands			
a!	Acknowledge	aM2!	Initiate Purge
al!	Identify	aC!-aC9!	Concurrent Measure
aV!	Verify	aCC!-aCC9!	Concurrent measure w/CRC
aM!-aM1!	Measure	aD0!-aD9!	Data Retrieval
aMC!-MC1!	Measure with CRC	aAn!	Change Address
Extended SDI-12 Commands			
aXSDEF!	Reset to Defaults	aXRPP!	Read Purge Pressure
aXWSn.nn!	Write Stage Slope	aXWPSnn!	Write Purge Sustain
aXRS!	Read Stage Slope	aXRPS!	Read Purge Sustain
aXSCSn.nn!	Set Current Stage	aXWIHn.nn!	Write 4-20mA Stage max
aXWOn.nn!	Write Stage Offset	aXRIH!	Read 4-20mA Stage Max
aXRO!	Read Stage Offset	aXWILn.nn!	Write 4-20mA Stage Min
aXWATnn!	Write Averaging Time	aXRIL!	Read 4-20mA Stage Min
aXRAT!	Read Averaging Time	aXWMEen!	Write Modbus enable
aXWSDn!	Write RS-232 Stage Digits	aXRMEen!	Read Modbus enable
aXRSD!	Read RS-232 Stage Digits	aXWAEen!	Write Auto enable
aXWBRnn!	Write Bubble Rate	aXRAEn!	Read Auto enable
aXRBR!	Read Bubble Rate	aXWMRnn!	Write Measure Rate
aXWPPnn!	Write Purge Pressure	aXRMR!	Read Measure Rate
aXTD!	Test Display	aXHELP!	Display a List of Commands

Note, the 'a' character in Table 4-2 represents the current SDI-12 address of the H-3553T and the 'n' characters represent the new value to be written. Each H-3553T extended SDI-12 command is discussed in more detail later in the chapter.

# SETUP & OPERATION

## Default Setup

The H-3553T has many settings that can be change. However, the default setups will normally cover most applications. Table 4-3 shows the default settings for the H-3553T.

Table 4-3: H-3553T Default Setup

Setting	Default Setting	Setting Range
SDI-12 Address	0	0-9 (Standard), A-Z, a-z
Stage Units	Feet (Slope = 2.3067)	Ft, In, M, mm, Ft Dn, Usr Def
Stage Offset	0.00	N/A
SDI-12 Stage Digits	3	N/A
RS-232 Stage Digits	2	
Averaging Time	2 Seconds	1-65535 seconds
Bubble Rate	60 bubbles/min	30-120 bubbles/min
Purge Pressure	40 PSI (15 PSI Sensor) 50 PSI (30 PSI Sensor)	30-90 PSI
Purge Sustain	20 seconds	10-40 seconds
4-20mA Min Stage	4.0	N/A
4-20mA Max Stage	20.0	N/A

## Reset to Defaults

It may be necessary to reset the H-3553T settings back to factory defaults. Using the RS-232 menu, press the 'P' key to enter the "Advanced Options" menu and then press the 'D' key to "Reset Defaults".

To reset to defaults using the SDI-12 interface, send the "aXSDEF!" SDI-12 extended command. The response should be "a0041" which means that it will take 4 seconds to reset to defaults. Note in Table 4-4, the 'a' is the current address of the H-3553T.

Table 4-4: Reset H-3553T to Factory Defaults

H-3553T Combo Bubbler Setup Menu	SDI-12 Interface
P - Advanced Options	Command: aXSDEF!
:	Response: a0041
Advanced Options Menu	
D - Reset Defaults	
Resetting to Defaults...	



## SDI-12

The SDI-12 address of a sensor is its identifier on the SDI-12 data bus. The SDI-12 data bus is a one wire communication between normally one master device and one or more slave devices. The SDI-12 address makes it possible for the master device to communicate with each sensor individually. SDI-12 data collisions will occur when two or more sensors have the same address on the same data bus. The sensors with the same address will try to respond to the request of the master device at the same time and the result is garbage data. Therefore, it is important to know the address of the sensor to which communication is desired and that there are no other sensors with the same address.

The H-3553T SDI-12 address by default is 0. To change the H-3553T SDI-12 address using the RS-232 main menu, press the 'A' key and enter in the new "SDI-12 address".

Table 4-5: Change the H-3553T SDI-12 Address

H-3553T Combo Bubbler Setup Menu	SDI-12 Interface
A - SDI-12 Address: a	Command: aAn!
Enter New SDI-12 Address [n]	Response: n

To change the H-3553T SDI-12 address using the SDI-12 interface, send the "aAn!" command and the response should be 'n', the new address. Note in Table 4-5, the 'a' is the current address of the H-3553T and the 'n' is the desired new SDI-12 address.

## Stage Units / Slope

The stage unit of a sensor is the setting that determines the data output units. Different data units are dependent on the slope/multiplier. The slope is multiplied by the raw data to achieve the desired units. For example, a pressure sensor raw data output might be in pressure (PSI) units, but the desired units by the user is feet. Therefore, the slope to convert PSI to Feet units for water depth is 2.0367 rounded.

The H-3553T has a pressure sensor that measures the pressure required to push a bubble out of the orifice line, which is the line pressure. The line pressure raw value is returned in pressure (PSI) units. Normally, water depth in feet or meters is the stage units desired. This then requires the line pressure value to be changed to a different set of units. Table 4-6 shows typical slopes required to convert pressure (PSI) units to other different stage units.

Table 4-6: H-3553T Stage Units and Slopes

Units	Slopes (multiplier)
Feet	2.3067
Meters	0.7031
Inches	27.6800
Millimeters	0.0007031
Centimeters	0.007031
Feet Down	-2.3067
PSI	1.0000

The H-3553T stage unit default is feet, which is a default slope of 2.0367. To change the stage units/slope using the RS-232 main menu, press the 'U' key and then the up and down arrow keys to toggle to the desired units, then press the 'Enter' key. If the desired stage unit is not listed change the stage units to user defined, press the 'L' key and enter in the desired slope.

To change the H-3553T stage slope using the SDI-12 interface, send the "aXWSn.nn!" SDI-12 extended command. The response should be "a0021" which means that it will take 2 seconds to complete the command and then it will put 1 data value in the buffer. To check the slope and verify it was written correctly send "aXRS!" and wait the responded time. Then send the "aD0!" command to read back the new slope.

# SETUP & OPERATION

Note Table 4-7, the 'a' is the current SDI-12 address of the H-3553T and the 'xxxx'/'x.xxx' is the current units/slope of the H-3553T and the 'nnnn'/'n.nnn' is the desired new units/slope.

Table 4-7: Change the H-3553T Units / Slope

H-3553T Combo Bubbler Setup Menu	SDI-12 Interface
U - Units: xxxx	Command: aXWSn.nnn!
Stage Units: [nnnn]	Response: a0021
L - Slope: x.xxx	Command: aXRS!
Enter Slope Value: [n.nnn]	Response: a0011
	Command: aD0!
	Response: a + n.nnn

## Set Current Stage

Set current stage is setting the stage to the actual measured or surveyed value, this could include the elevation or not. Normally, the current stage value comes from a wire weight reading or a surveyed staff gauge reading.

Setting the current stage in the H-3553T forces a new measurement and then compares the result of that measurement with the desired current stage and then calculates and sets the stage offset. To set the current stage using the RS-232 main menu, press the 'S' key, enter in the current "Stage" and then press the 'Enter' key.

To set current stage using the SDI-12 interface, send the "aXSCSn.nn!" SDI-12 extended command. The response should be "a0061" which means that it will take 6 seconds to complete the command and then it will put 1 data value in the buffer. To check if the stage was set correctly, send the "aM!" measurement command, wait the responded time and then send the "aD0" and verify the stage level value. Note Table 4-8, the 'a' is the current SDI-12 address of the H-3553T and the 'x.xxx' is the current measured stage of the H-3553T and the 'n.nnn' is the desired new current stage.

Table 4-8: Set the H-3553T Current Stage

H-3553T Combo Bubbler Setup Menu	SDI-12 Interface
S - Stage: x.xxx	Command: aXSCSn.nnn!
Enter Stage Value: [n.nnn]	Response: a0061
	Command: aM!
	Response: a0066
	Command: aD0!
	Response: a+n.nnn+...

Note: The last section of this chapter discusses the "Set Current Stage" section as the most used option.

## Stage Offset

The stage offset is a value that is added to the final stage result after the slope/multiplier has been applied. The stage offset is normally used to obtain a final stage level relative to some reference point such as sea level. Writing the stage offset is not needed when using the set current stage option, because this option calculates and sets the stage offset automatically.

The H-3553T stage offset default is 0.000. To change the stage "Offset" using the RS-232 main menu, press the 'O' key, enter the new stage offset and then press the 'Enter' key.

To change the H-3553T stage offset using the SDI-12 interface, send the "aXWOn.nn!" SDI-12 extended command. The response should be "a0021" which means that it will take 2 seconds to complete the command and then it will put 1 data value in the buffer. To check the offset and verify it was written correctly send "aXRO!" and wait the responded time. Then send the "aD0!" command to read back the new offset. Note Table 4-9, the 'a' is the current SDI-12 address of the H-3553T and the 'x.xxx' is the current offset of the H-3553T and the 'n.nnn' is the desired new stage offset.

Table 4-9: Change the H-3553T Stage Offset

H-3553T Combo Bubbler Setup Menu	SDI-12 Interface
O - Offset: x.xxx	Command: aXWOn.nnn!
Enter Offset Value: [n.nnn]	Response: a0021
	Command: aXRO!
	Response: a0011
	Command: aD0!
	Response: a + n.nnn

## Stage Averaging Time

The stage averaging time is the setting that determines how long in seconds the H-3553T will average the measurements before returning the final stage value. It is important to sample multiple times to ensure accuracy of a reading, especially if the water is rough. The stage averaging time may need to be adjusted to help smooth out choppy data due to wave action.

The H-3553T stage averaging time default is 2 seconds, which is equal to about 10 samples. The stage averaging time range is 1 to 65535 seconds. To change the averaging time using the RS-232 main menu, press the 'P' key to enter the "Advanced Options" menu, then press the 'T' key, enter in the new "Averaging Time" and press the 'Enter' key.

To set the stage averaging time using the SDI-12 interface, send the "aXWATnn!" SDI-12 extended command. The response should be "a0021" which means that it will take 2 seconds to complete the command and then it will put 1 data value in the buffer. To check if the averaging time was set correctly, send "aXRAT!" command, wait the responded time and then send the "aD0" and verify the averaging time value. Note Table 4-10, the 'a' is the current SDI-12 address of the H-3553T and the 'x' is the current averaging time of the H-3553T and the 'n' is the desired stage averaging time.

# SETUP & OPERATION

Note: This averaging time does not take into account the time it takes to make an atmospheric reading. Therefore, always add about 4 more seconds to the averaging time to calculate how long the full measurement cycle can take.

Table 4-10: Change the H-3553T Stage Averaging Time

H-3553T Combo Bubbler Setup Menu	SDI-12 Interface
P - Advanced Options	Command: aXWATn!
:	Response: a0021
<b>Advanced Options Menu</b>	Command: aXRAT!
T - Averaging Time: x	Response: a0011
Averaging Time [ nnn ]	Command: aD0!
	Response: a + nnn

## RS-232 Stage Digits

The RS-232 stage digits are the setting that determines how many digits are displayed to the right of the decimal place for the measured value when printed out the RS-232 port. Normally, two digits to the right of the decimal place is the standard when measuring stage in feet.

The H-3553T RS-232 stage digits default is 2. To change the "Stage Digits" using the RS-232 main menu, press the 'D' key, enter in the new stage digits and then press the 'Enter' key.

To change the H-3553T RS-232 stage digits using the SDI-12 interface, send the "aXWSDn!" SDI-12 extended command. The response should be "a0021" which means that it will take 2 seconds to complete the command and then it will put 1 data value in the buffer. To check the stage digits and verify it was written correctly send "aXRSD!" and wait the responded time. Then send the "aD0!" command to read back the new stage digits. Note Table 4-11, the 'a' is the current SDI-12 address of the H-3553T and the 'x' is the current stage digits of the H-3553T and the 'n' is the desired new stage digits.

Table 4-11: Change the H-3553T RS-232 Stage Digits

H-3553T Combo Bubbler Setup Menu	SDI-12 Interface
D - Digits: x	Command: aXWSDn!
Stage Digits: [n]	Response: a0021
	Command: aXRSD!
	Response: a0011
	Command: aD0!
	Response: a+n

## Bubble Rate

The bubble rate is the average number of bubbles flowing from the end of the orifice line per minute. The standard orifice line tubing that we recommend and calibrate the bubble rate has 1/8 inch inner diameter (I.D.). If a different size orifice I.D. is used the bubble rate will not be correct.

The bubble rate is a determining factor in the response time of the H-3553T tracking a rise in stage. Table 4-12

shows the approximate time needed to respond and track a one foot rise in stage with different bubble rates. Note this is at a depth of one foot, at greater depths the time will increase slightly.

Another reason for changing the bubble rate may be to reduce noise in the data. Some sites have turbulent water conditions creating water level data that looks jittery. The bubble rate may be changed, up or down, to find optimal results to reduce this noise. Normally, it is a combination of changing the bubble rate and the mean count/samples to produce the best results. The default values normally work best in the majority of the applications and provide desirable results in a timely manner.

The H-3553T bubble rate default is set to 60 bubbles/min. The bubble rate range is 30 to 120 bubbles/min. To change the bubble rate using the RS-232 main menu, press the 'B' key to enter the "Bubbler Settings" menu, then press the 'B' key, enter in the new desired "Bubble Rate" and press the 'Enter' key.

To change the H-3553T bubble rate using the SDI-12 interface, send the "aXWBRnn!" SDI-12 extended command. The response should be "a0061" which means that it could take 6 seconds to complete the command and then it will put 1 data value in the buffer. To check the bubble rate and verify it was written correctly send "aXRBR!" command and wait the responded time. Then send the "aD0!" command to read back the new bubble rate. Note Table 4-13, the 'a' is the current SDI-12 address of the H-3553T and the 'xx' is the current bubble rate of the H-3553T and the 'nn' is the desired bubble rate.

Table 4-12: Bubble Rate vs. Response Time

Bubble Rate	Response for 1 Ft. Rise
30 bubbles/min	25 seconds
60 bubbles/min	20 seconds
120 bubbles/min	15 seconds

Table 4-13: Change the H-3553T Bubble Rate

H-3553T Combo Bubbler Setup Menu	SDI-12 Interface
B - Bubbler Settings	Command: aXWBRnn!
:	Response: a0061
<b>Bubbler Settings Menu</b>	Command: aXRBR!
B - Bubbler Rate: xx	Response: a0021
Enter Bubble Rate (30 -120) [ nn ]	Command: aD0!
	Response: a + nn

# SETUP & OPERATION

## Purge

The H-3553T has an option built in called purge, the purpose of the purge is to clear out any debris or silt from the end of the orifice line that could cause false pressure readings.

When a purge is initiated the H-3553T makes a new measurement on the line and tank sensor and saves the values away just in case data is requested during the purge. The compressor is then turned on and begins compressing air into the tank until the tank pressure is equal to or greater than the purge pressure value. The purge valve is then opened which then releases the tank pressure into the orifice line. The compressor will continue to run until the purge sustain timer has elapsed. Then the H-3553T monitors the tank pressure which is still open to the orifice and waits for it to stabilize. Finally, the purge valve closes and the H-3553T purge process is complete. Shortly following the purge sequence the H-3553T will need to recharge the tank pressure to maintain the bubble rate and continue normal operation.

There are three ways to initiate a purge, push the "PURGE" button, the RS-232 menu, and the SDI-12 interface. To initiate a purge with the button, open the H-3553T enclosure lid and locate the a white push button on the circuit board labeled "PURGE", press and hold for about 2 seconds.

To initiate a purge using the RS-232 main menu, press 'B' key to enter the "Bubbler Settings" menu and then press the 'M' key for "Manual Purge". To initiate a purge using the SDI-12 interface, send the "aXP!" command or the "aM2!" command. Note Table 4-14, the 'a' is the current SDI-12 address of the H-3553T. The 'ttt' is the time it will take to complete the purge, which is dependent on other factors like averaging time and purge sustain. The 'dd.d' is the compressor battery voltage measured immediately following the completed purge sequence.

Table 4-14: Initiate H-3553T Purge

H-3553T Combo Bubbler Setup Menu	SDI-12 Interface
B - Bubbler Settings	Command: aXP! / aM2!
:	Response: attt1
<b>Bubbler Settings Menu</b>	Command: a + dd.d
M - Manual Purge	Response: a + dd.d
Initiating Purge . . .	

## Purge Pressure

The purge pressure is the pressure that is used to purge the orifice line. This is normally done to clear the end of the orifice line of debris and or sediment buildup. "False high stage" readings can be caused by debris or sediment buildup at the end of the orifice line. This is because it will cause more restriction when trying to push a bubble out which is like the stage is rising. This may cause a saw tooth profile in your data. As pressure keeps building up until the bubble pushes out past the debris or sediment relieving the pressure in the line. Then the pressure starts building up again causing saw tooth data.

The H-3553T purge pressure default is set to 40 PSI (15 PSI sensor) or 50 PSI (30 PSI sensor). The programmable purge pressure range is 30 to 90 PSI. To change the "Purge Pressure" using the RS-232 main menu, press the

'B' key to enter the "Bubbler Settings" menu and then press the 'P' key, then enter in the desired purge pressure and press the 'Enter' key.

To change the H-3553T purge pressure using the SDI-12 interface, send the "aXWPPnn!" SDI-12 extended command. The response should be "a0061", which means that it could take 6 seconds to complete the command and then it will put 1 data value in the buffer. To check the new purge pressure, send "aXRPP!" command and wait the responded time. Send the "aD0!" command to read back the new written purge pressure. Note Table 4-15, the 'a' is the current SDI-12 address of the H-3553T and the 'xx' is the current purge pressure of the H-3553T and the 'nn' is the desired purge pressure.

Table 4-15: Change the H-3553T Purge Pressure

H-3553T Combo Bubbler Setup Menu	SDI-12 Interface
B - Bubbler Settings	Command: aXWPPnn!
:	Response: a0061
<b>Bubbler Settings Menu</b>	Command: aXRPP!
P - Purge Pressure: xx	Response: a0021
Enter Purge Pressure (15 - 90) [ nn ]	Command: aD0!
	Response: a + nn

### Purge Sustain

The purge sustain is part of the purge sequence discussed earlier, it is the time in seconds that the compressor will keep running after the tank pressure is released into the orifice line. The purge sustain helps clear out heavier sediment buildup and or bigger blocks at the end of the orifice because of sustaining a higher pressure.

The H-3553T purge sustain default time is set to 20 seconds. The programmable purge sustain range is 10 to 40 seconds. To change the purge sustain time using the RS-232 main menu, press the 'B' key to enter the "Bubbler Settings" menu and then press the 'S' key, enter in the desired "Purge Sustain" time and then press the 'Enter' key.

To change the H-3553T purge sustain using the SDI-12 interface; send the "aXWPSnn!" SDI-12 extended command. The response should be "a0061", which means that it could take 6 seconds to complete the command and then it will put 1 data value in the buffer. To check the new purge sustain time, send "aXRPS!" command and wait the responded time. Send the "aD0!" command to read back the new written purge sustain time. Note Table 4-16, the 'a' is the current SDI-12 address of the H-3553T and the 'xx' is the current purge sustain time of the H-3553T and the 'nn' is the desired purge sustain time.

# SETUP & OPERATION

Table 4-16: Change the H-3553T Purge Sustain

H-3553T Combo Bubbler Setup Menu	SDI-12 Interface
B - Bubbler Settings	Command: aXWPSnn!
:	Response: a0061
<b>Bubbler Settings Menu</b>	Command: aXRPS!
S - Purge Sustain: xx	Response: a0021
Enter Purge Sustain (10 - 40) [ nn ]	Command: aD0!
	Response: a + nn

## 4-20 Milliamp Output

The H-3553T has the ability to output the stage value as a 4-20 milliamp signal. The 4-20 milliamp output is most commonly used in industrial applications with PLC's or SCADA systems. The H-3553T controls the loop current but does not power the loop. Therefore, the loop must be externally powered. Figure 4-1 shows a basic wiring diagram for a 4-20 milliamp output loop with the H-3553T. The battery in the loop should be a +24VDC power source.

Figure 4-1: Typical H-3553T 4-20 mA Output Setup

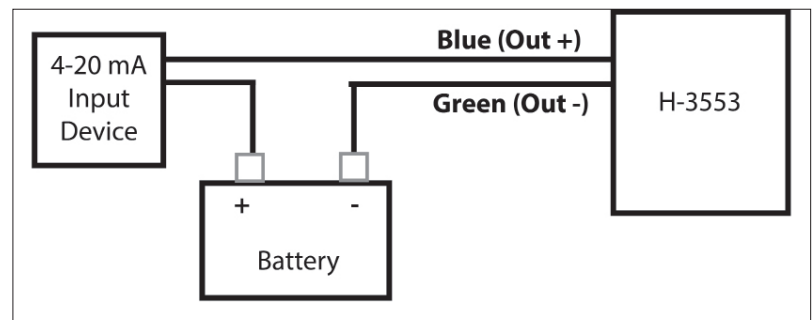

The H-3553T scales the current measured stage reading for the 4-20 milliamp output based on the 4-20 milliamp min and max stage values.

## 4-20 Milliamp Min Stage

The 4-20 milliamp min stage value should be the lowest the stage gets at the installed site. When the stage equals this value or lower the 4-20 milliamp out put will be 4.0 milliamps, the min.

The H-3553T 4-20 milliamp min stage default value is set to 4. There is no limit to this value, but keep in mind that the smaller the overall range of the 4-20 stage scalar, which is the min to the max stage, the more accurate the 4-20 milliamp output will be. To change the 4-20 milliamp min stage using the RS-232 main menu, press the 'P' key to enter the "Advanced Options" menu and then press the 'F' key to enter the "4-20mA Output Setup" menu. Then press the 'N' key in this menu and enter in the new "Min Stage" value and press the 'Enter' key.

To change the H-3553T 4-20 milliamp min stage using the SDI-12 interface, send the "aXWILn.nn!" SDI-12 extended command. The response should be "a0021", which means that it could take 2 seconds to complete the command and then it will put 1 data value in the buffer. To check the new 4-20 milliamp min stage, send "aXRIL!" command and wait the responded time. Then send the "aD0!" command to read back the new written 4-20 milliamp min stage. Note Table 4-17, the 'a' is the current SDI-12 address of the H-3553T and the 'x.xx' is the current 4-20 milliamp min stage and the 'n.nn' is the desired 4-20 milliamp min stage.



Table 4-17: Change the H-3553T 4-20 Milliamp Min Stage

H-3553T Combo Bubbler Setup Menu	SDI-12 Interface
P - Advanced Options	Command: aXWILn.nn!
:	Response: a0021
<b>Advanced Options Menu</b>	Command: aXRIL!
F - 4-20 mA Output	Response: a0011
:	Command: aD0!
<b>4-20 mA Output Setup Menu</b>	Response: a + n.nn
N - Min Stage: x.xx	
Enter 4 - 20mA Min Stage [ n.nn ]	

### 4-20 Milliamp Max Stage

The 4-20 milliamp max stage value should be the highest the stage gets at the installed site. When the stage equals this value or greater the 4-20 milliamp output will be 20.0 milliamps, the max.

The H-3553T 4-20 milliamp max stage default value is set to 20. There is no limit to this value, but keep in mind that the smaller the overall range of the 4-20 stage scalar, which is the min to the max stage, the more accurate the 4-20 milliamp output will be. To change the 4-20 milliamp max stage using the RS-232 main menu, press the 'P' key to enter the "Advanced Options" menu and then press the 'F' key to enter the "4-20mA Output Setup" menu. Then press the 'X' key in this menu, enter in the new "Max Stage" value and press the 'Enter' key.

To change the H-3553T 4-20 milliamp max stage using the SDI-12 interface, send the "aXWIHn.nn!" SDI-12 extended command. The response should be "a0021", which means that it could take 2 seconds to complete the command and then it will put 1 data value in the buffer. To check the new 4-20 milliamp max stage, send "aXRIH!" command and wait the responded time. Then send the "aD0!" command to read back the new written 4-20 milliamp max stage. Note Table 4-18, the 'a' is the current SDI-12 address of the H-3553T and the 'x.xx' is the current 4-20 milliamp max stage and the 'n.nn' is the desired 4-20 milliamp max stage.

Table 4-18: Change the H-3553T 4-20 Milliamp Max Stage

H-3553T Combo Bubbler Setup Menu	SDI-12 Interface
P - Advanced Options	Command: aXWIHn.nn!
:	Response: a0021
<b>Advanced Options Menu</b>	Command: aXRIH!
F - 4-20 mA Output	Response: a0011
:	Command: aD0!
<b>4-20 mA Output Setup Menu</b>	Response: a + n.nn
X - Min Stage: x.xx	
Enter 4 - 20mA Max Stage [ n.nn ]	

# SETUP & OPERATION

## Modbus Mode Enable

The Modbus mode enable is the setting that determines whether the H-3553T will communicate with a Modbus master device. Modbus is an industry standard serial digital interface for interconnecting Programmable Logic Controllers (PLCs), intelligent sensors and other devices. The H-3553T can be used as a Modbus slave and has a serial RS-485 port for connecting to a Modbus compatible host device. See the “Chapter 5 Modbus Operation” for more information on Modbus settings Modbus register definitions. Note: this mode requires more power because it does not go to sleep, the normal operation current draw increase to about 14mA instead of normal mode of about 6mA.

The H-3553T Modbus mode enable default is 0 meaning disabled/off. To enable the “Modbus Mode” using the RS-232 main menu, press the ‘P’ key to enter the “Advanced Options” menu and then press the ‘M’ key to enter the “Modbus Setup” menu. Then press the ‘M’ key in this menu and the Modbus mode enable will change to on.

To change the H-3553T Modbus mode enable using the SDI-12 interface, send the “aXWME1!” SDI-12 extended command to enable or change the ‘1’ to a 0 to disable. The response should be “a0021” which means that it will take 2 seconds to complete the command and then it will put 1 data value in the buffer. To check the Modbus mode enable and verify it was written correctly send “aXRME!” and wait the responded time. Then send the “aD0!” command to read back the Modbus mode enable. Note Table 4-19, the ‘a’ is the current SDI-12 address of the H-3553T and the ‘n’ is the desired Modbus mode enable “1 = On” or “0 = Off”.

Table 4-19: Change the H-3553T Modbus Mode Enable

H-3553T Combo Bubbler Setup Menu	SDI-12 Interface
P - Advanced Options	Command: aXWME! Response: a0021
:	
<b>Advanced Options Menu</b>	Command: aXRME!
M - Modbus Setup	Response: a0021
:	Command: aD0!
<b>Modbus Settings Menu</b>	Response: a + n
M - Modbus Off/On	

## Auto Mode Enable

The Auto mode enable is the setting that determines whether the H-3553T is put in a unique mode. When in this mode the H-3553T does not go to sleep but stays awake and based on a user defined measure rate measures itself and updates all the outputs like 4-20mA, RS-232, and the SDI-12 buffer. This mode makes it possible for the H-3553T to run on its own completely independent of a data logger or master device. Note: this mode requires more power because it does not go to sleep, the normal operation current draw increase to about 14mA instead of normal mode of about 6mA.

The H-3553T Auto mode enable default is 0 meaning disabled/off. To enable the “Auto Mode” using the

RS-232 main menu, press the 'P' key to enter the "Advanced Options" menu. Then under the "Measurement Options" section press the 'A' key and the Auto mode enable will change to on.

To change the H-3553T Auto mode enable using the SDI-12 interface, send the "aXWAE1!" SDI-12 extended command to enable or change the '1' to a 0 to disable. The response should be "a0021" which means that it will take 2 seconds to complete the command and then it will put 1 data value in the buffer. To check the Auto mode enable and verify it was written correctly send "aXRAE!" and wait the responded time. Then send the "aD0!" command to read back the Auto mode enable. Note Table 4-20, the 'a' is the current SDI-12 address of the H-3553T and the 'n' is the desired Auto mode enable "1 = On" or "0 = Off".

Table 4-20: Change the H-3553T Auto Mode Enable

H-3553T Combo Bubbler Setup Menu	SDI-12 Interface
P - Advanced Options	Command: aXWAE!
:	Response: a0021
<b>Advanced Options Menu</b>	Command: aXRAE!
A - Automode Off/On	Response: a0021
	Command: aD0!
	Response: a + n

### Measure Rate (Auto Mode Enabled)

The Measure Rate is the time in minutes the H-3553T will update itself and outputs when in auto mode (see section Auto Mode Enable). This is useful in the application where the H-3553T is no connected to a master device to say when to measure and give data.

The H-3553T Measure Rate default time is set to 1 minute. The programmable measure rate range is 0 to 255 minutes. Note: When the measure rate is set to 0 minutes the H-3553T will measure itself as fast as it can. This speed is dependent on the averaging time setting and also when doing this the atmospheric pressure reading will be measured about every 3 ½ minutes rather than every measurement. To change the measure rate

using the RS-232 main menu, press the 'P' key to enter the "Advanced Options" menu. Then found under the "Measurement Options" section, press the 'R' key and enter in the desired auto mode measure rate.

To change the H-3553T measure rate using the SDI-12 interface, send the "aXWMRnn!" SDI -12 extended command. The response should be "a0021", which means that it could take 2 seconds to complete the command and then it will put 1 data value in the buffer. To check the new measure rate, send "aXRMR!" command and wait the responded time. Send the "aD0!" command to read back the new written measure rate. Note Table 4-21, the 'a' is the current SDI-12 address of the H-3553T and the 'xx' is the current measure rate of the H-3553T and the 'nnn' is the desired measure rate time.

# SETUP & OPERATION

Table 4-21: Change the H-3553T Measure Rate

H-3553T Combo Bubbler Setup Menu	SDI-12 Interface
P - Advanced Options	Command: aXWMRnnn!
:	Response: a0021
<b>Advanced Options Menu</b>	Command: aXRMR!
R - Measure Rate: xx	Response: a0021
Enter Measure Rate (0 - 255) [nnn ]	Command: aD0!
	Response: a + nnn

## Test Display

If the display seems to be displaying numbers incorrectly, the Test Display command can be used to verify the individual segments are working properly. This command cycles the numbers 0-9 in each number location then displays 100.000, 1000.00, and 10000.0 to ensure the decimals are also working properly.

## Help

The Help command outputs a complete list of commands that this unit supports. The response is not SDI-12 compliant but many devices in a transparent mode can display the table of commands.

## Setup and Operation Conclusion

This chapter has focused on the setup and operation of the H-3553T. Although there are many settings, most applications will work just fine with the default settings. WaterLOG has put great efforts in testing and adjusting the default settings to fit most applications, therefore try using the default settings, and then make adjustments as needed.

The option that will probably be of most importance in this chapter is the "Set Current Stage" section. Once the H-3553T is mounted and installed, the last thing to do is set the current stage. All the other settings found in this chapter will only need to be changed if the default settings will not work for the application.

And of course, with all WaterLOG equipment, if there is ever a question or more explanation needed or a problem that needs extra assistance call or email us and we will gladly assist you with the product.

Phone: 435-753-2212

Email: [support@waterlog.com](mailto:support@waterlog.com) or [environmental@ysi.com](mailto:environmental@ysi.com)



# 05 / MODBUS OPERATION

---

# MODBUS OPERATION

The H-3553T supports a Modbus client protocol interface. Modbus is an industry standard field bus for interconnecting Programmable Logic Controllers (PLCs), intelligent sensors and other devices. The H-3553T communicates Modbus via the RS-485 serial port connections; see Chapter 2 Table 2-1 for wiring connections. This chapter will focus on Modbus setup and operation using the RS-232 menu interface or the SDI-12 interface.

**Note:** Modbus communication is only available when the system is not busy performing other requested tasks (i.e. purging, automode with the rate set to zero, SDI-12 commands, etc.)

## Communication Setup

The Modbus communication interface is designed to work with a Modbus Host device like PLC's, etc. The host must support RTU (Remote Terminal Unit) mode to communicate with the H-3553T. Table 5-1 shows the default settings required to communicate with the H-3553T through the RS-485 Modbus interface port. For more information regarding Modbus RTU communication protocol and specifications see [www.modbus.org](http://www.modbus.org).

Table 5-1: H-3553T RS-485 Modbus Comm Settings

Setting	Default Setting
Baud Rate	9600
Data Bits	8
Stop Bits	1
Parity	Even
Protocol	RTU

## Function Codes

Modbus Function Codes are codes that are part of the Modbus command that specify what is being requested via the Modbus protocol. The H-3555 supports two Modbus function codes. Table 5-2 shows the supported function codes.

Table 5-2: H-3553T Supported Modbus Function Codes

Function Code	Description	# of Registers
03	Read Holding Registers	41
16	Write Multiple Registers	41

## Holding Registers

The H-3553T has 41 Holding Registers; these registers contain all the needed data for setup and measuring the H-3553T. Table 5-3 is a list of the holding registers available.

Table 5-3: H-3553T Holding Registers

Register Description	Start Address	# of 16-bit Registers	Data Type
*ID String	0 / "0000"	16	Char String
Modbus Address	16 / "0010"	1	Short Integer
Stage Units	17 / "0011"	1	Short Integer
Reserved	18 / "0012"	1	Short Integer
Baudrate	19 / "0013"	1	Short Integer
Parity	20 / "0014"	1	Short Integer
Bubble Rate	21 / "0015"	1	Short Integer
Purge Pressure	22 / "0016"	1	Short Integer
Purge Sustain	23 / "0017"	1	Short Integer
Purge	24 / "0018"	1	Short Integer

## Modbus Operation

Stage Offset	25 / "0019"	2	32 Bit Float
Stage Slope	27 / "001B"	2	32 Bit Float
*Stage	29 / "001D"	2	32 Bit Float
*Pressure	31 / "001F"	2	32 Bit Float
*Temperature	33 / "0021"	2	32 Bit Float
*Control Battery	35/"0023"	2	32 Bit Float
*Tank Pressure	37 / "0025"	2	32 Bit Float
*Compressor Battery	39 / "0027"	2	32 Bit Float
<i>*Note: These registers are read only; there is no effect if written.</i>			

### ID String Registers

The ID String is the first set of registers in the Holding Registers; these registers return the same information that the SDI-12 ID command returns. The ID string consists of 16, 16-bit registers in ASCII character data format. These registers can be read separately but to get the full ID string the user must read all 16-registers at once. These registers are read only registers; however, writing to them will have no effect. As shown in Table 5-3 the response to reading the ID string is sent as ASCII character string.

### Modbus Address Register

The Modbus Address holding register allows the user to change the Modbus address of the H-3553T. A Modbus host / master device can be connected to many Modbus slave devices at one time. Therefore, the Modbus address is a device identifier. This register must be read and wrote as a short integer.

The default Modbus address for the H-3553T is 1 and the programmable address range is: 1 - 247. Address "0" is reserved as the broadcast address meaning that all Modbus sensors must listen when commands are sent to address "0".

### Stage Units Select Register

The Stage Units holding registers allows the user to change the units of the final measured stage value. Table 5-4 shows what the stage units holding register must be set to obtain the desired units. The H-3553T default stage units are in feet. In the case that there is a user defined units, first change the stage units select to '06' and then write the slope manually. Writing the stage slope before setting stage units to user defined will have no effect. This register must be read and wrote as a short integer.

Table 5-4: Stage Units Select Register Options

Register Value	Stage Units
00	Feet (Default)
01	Meters
02	Inches
03	Millimeters
04	Centimeters
05	PSI
06	User Defined

# MODBUS OPERATION

## Baudrate Select Registers

The Baudrate holding register allows the user to change the baud rate of the Modbus RS-485 serial port. Table 5-5 shows what the Modbus baudrate holding register should be set to get the desired baudrate. The H-3553T default baudrate is 9600. When the user changes the baud rate it does not take effect until the power is cycled. This register must be read and wrote as a short integer.

Table 5-5: Baud Rate Select Register Options

Register Value	Stage Units
00	9600 (Default)
01	4800
02	2400
03	1200

## Parity Select Registers

The Parity holding register allows the user to change the pairity of the Modbus RS-485 serial port communication. Table 5-6 shows what the parity holding register should be set to get the desired parity.

Table 5-6: Parity Select Register Options

Register Value	Stage Units
00	None
01	Even (Default)
02	Odd

## Bubble Rate Register

The Bubble Rate holding register allows the user to change the bubble rate. See Chapter 4 - Bubble Rate for more information. This register must be read and wrote as a short integer.

## Purge Pressure Register

The Purge Pressure holding register allows the user to change the purge pressure. See Chapter 4 - Purge Pressure for more information. This register must be read and wrote as a short integer.

## Purge Sustain Register

The Purge Sustain holding register allows the user to change the purge sustain time. See Chapter 4 - Purge Sustain for more information. This register must be read and wrote as a short integer.

## Purge Register

The Purge holding register allows the user to initiate a purge sequence. Writing a '1' to this register will initiate a purge sequence. See Chapter 4 - Purge for more information. This register must be read and wrote as a short integer.

## Stage Offset Register

The Stage Offset holding register allows the user to enter a user defined stage offset. The factory default is 0. See Chapter 4 - Stage Offset for more information. This holding register is a 32-bit holding register. Therefore, the value sent to write to this register must be in a 32-bit floating point number format.



### Stage Slope Register

The Stage Slope holding register allows the user to enter a user defined stage slope. Writing to this register is only applicable when the Stage Units Select Register is set to 06, which indicates the user defined mode for the units. The factory default slope is 2.3067, which is the slope for stage unit's feet. See Chapter 4 - Stage Slope for more information. This holding register is a 32-bit holding register. Therefore, the value sent to write to this register must be in a 32-bit floating point number format.

### Stage Register

The Stage holding register holds the current measured stage value. This holding register is a 32-bit holding register. Stage is the result of the pressure in the line multiplied by the stage slope and added to the stage offset.

### Pressure Register

The Pressure holding register holds the current measured pressure value before the slope and offset is applied. Therefore, it holds the raw PSI value. This holding register is a 32-bit holding register.

### Temperature Register

The Temperature holding register holds the current measured temperature. The temperature reading is the temperature of the internal pressure sensor and may not accurately reflect air temperature.

### Control Battery Register

The Control Battery holding register holds the current measured battery connected to the control circuit board or sensor interface cable power connections. This holding register is a 32-bit holding register.

### Tank Pressure Register

The Tank Pressure holding register holds the current measured tank pressure value. This holding register is a 32-bit holding register.

### Compressor Battery Register

The Compressor Battery holding register holds the current measured battery connected to the compressor power input on the H-3553T box. This holding register is a 32-bit holding register.

### Modbus Command Examples

Below are some examples of Modbus commands and their format.

Example #1: Read Holding Register Command:

Format: "aabbcccddeeee"

Where:

- aa = 1 byte Modbus address
- bb = 1 byte function code
- ccc = 2 byte start address
- ddd = 2 byte quantity of registers
- eee = 2 byte crc check

Example: 010300010001D5CA

# MODBUS OPERATION

---

Example #2: Write Multiple Registers Command:

Format: "aabbccccddddeefffgggg"

Where:

- aa = 1 byte Modbus address
- bb = 1 byte function code
- cccc = 2 byte start address
- dddd = 2 byte quantity of registers
- ee = byte count
- fff = 2 byte data value
- ggg = 2 byte crc value

Example: 011000010001022000BE41

This user manual is a guide for the H-3553T. For more information, updated manuals, brochures, technical notes, and supporting software on the H-3553T, please refer to [waterlog.com/3553](http://waterlog.com/3553) or contact your sales representative.

For additional assistance, please contact us at +1.435.753.2212 or [sales@waterlog.com](mailto:sales@waterlog.com)

# Xylem

- 1) The tissue in plants that brings water upward from the roots;
- 2) a leading global water technology company.

We're 12,000 people unified in a common purpose: creating innovative solutions to meet our world's water needs. Developing new technologies that will improve the way water is used, conserved, and re-used in the future is central to our work. We move, treat, analyze, and return water to the environment, and we help people use water efficiently, in their homes, buildings, factories and farms. In more than 150 countries, we have strong, long-standing relationships with customers who know us for our powerful combination of leading product brands and applications expertise, backed by a legacy of innovation.

**For more information on how Xylem can help you, go to [www.xyleminc.com](http://www.xyleminc.com)**



a xylem brand

**YSI Incorporated**  
1700/1725 Brannum Lane  
Yellow Springs, Ohio, 45387, USA

**Request a Quote**  
Tel: +1.435.753.2212  
Email: [sales@waterlog.com](mailto:sales@waterlog.com)  
Internet: [www.waterlog.com](http://www.waterlog.com)

**Place an Order**  
Tel: +1.937.767.7241  
Email: [orders@ysi.com](mailto:orders@ysi.com)

**Customer Support**  
Tel: +1.937.767.2772